

Geethanjali College of Engineering and Technology (Autonomous)
(Approved by AICTE, Permanently Affiliated to JNTUH, Accredited by NAAC with 'A' Grade)
Cheeryal (V), Keesara (M), Medchal Dist., Telangana - 501 301

3.1.2: The institution provides seed money to its teachers for research

S.No	Name of the teacher provided with seed money	The amount of seed money (INR in Lakhs)	Year of receiving	Page No
1	Drill Bit Extreme Anti Plagarism Software	0.682	2020-2021	1-6
2	O.V.P.R.Shiva kumar	0.299	2020-2021	7-9,15
3	P.Naresh kumar(Automated Titrator)	0.137	2020-2021	10-15
4	O.V.P.R.Shiva kumar	0.315	2020-2021	16-22
5	Y.V.N. Phani Kishore (Build My Project - Humanoid Robo)	3.808	2020-2021	23-31
6	Amount spent for e-Resources(IEEE, DELNET, KHUB, NLIST) and Journals	11.890	2020-2021	32-33
7	List Enclosed (Seed Money for Publications)	1.015	2020-2021	34
8	List Enclosed (Seed Money for FDP)	0.197	2020-2021	35
TOTAL		18.343		

*** Enclosed Proof's as per the list**

**GEETHANJALI COLLEGE OF ENGINEERING&TECHNOLOGY
(UGC AUTONOMOUS)
Cheeryal (V), Keesara (M), Medchal Dist. TS- 501 301**

Mechanism of detecting Plagiarism

Objectives

- To promote integrity in research.
- To protect ethical considerations in conducting research.
- To facilitate standardized documentation of research .
- To promote standards and practices for discouraging plagiarism.

Tool for checking plagiarism

In order to promote ethical research, the institution mandates that students to check their work plagiarism. UG/PG students must ensure that the similarity index is below 20%, as is required by most journals. They should submit evidence proving of the same.

The college uses the “Drill Bit” plagiarism detecting licensed software for checking plagiarism in the following documents:

- 1) Faculty publications
- 2) UG/PG Thesis
- 3) UG/PG paper publications and
- 4) M.Tech project reports

PRINCIPAL
Geethanjali College of Engg. and Tech.
Cheeryal (V), Keesara (M), Medchal Dist.(T.S.)-501 301.



Home Page**Instructions :**

1. Create a Folder
2. Select the folder to submit the document

Folders

SI No	Folder ID	Folder Name ↕	Status	Creation Date ↕	Action
1	89510	Ravi Shankar	active	2022-04-30	Edit ▾ Select
2	89465	krishnasoo943	expired	2022-04-29	Edit ▾ Select
3	83862	KrisnaPriya	expired	2022-01-30	Edit ▾ Select
4	82950	Rakesh1	expired	2022-01-19	Edit ▾ Select
5	82221	Naupal	expired	2022-01-12	Edit ▾ Select
6	81909	Rakesh	expired	2022-01-09	Edit ▾ Select
7	80928	ANIL	expired	2021-12-29	Edit ▾ Select
8	77625	Suresh	expired	2021-11-13	Edit ▾ Select
9	75269	MBA 2019	expired	2021-10-03	Edit ▾ Select

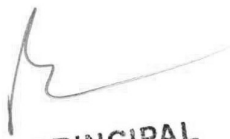
PRINCIPAL
 Geethanjali College of Engg. and Tech.
 Cheeryal (V), Keesara (M), Medchal Dist.(T.S.)-501 301.

TAX INVOICE

ORIGINAL FOR RECIPIENT



From

Pinnacle Nanotech India Pvt Ltd
11-8-237/4/204, C S Nilayam, Kranthi Nagar Colony,
Saroornagar,, Hyderabad, Telangana 500035

GSTIN 36AAFCP4375H1Z7
PAN AAFCP4375H

Invoice No. : INV/TS/20041
Invoice Date : 09/02/2021
Reference No : -
Place of supply : 36-Telangana
Due Date : 09/02/2021

Billing Address

Geethanjali College of Engineering and Technology
Cheeryal Village, Keesara Mandal, Medchal District., Hyderabad,
Telangana 501301, Telangana

Shipping Address

Geethanjali College of Engineering and Technology
Cheeryal Village, Keesara Mandal, Medchal District., Hyderabad,
Telangana 501301, Telangana

#	Description	HSN / SAC	Qty	Rate / Unit	Taxable Value	CGST	SGST / UTGST	Total Amount
1	DrillBit Extreme Anti Plagiarism software - 500 Document Submissions one user account 12 months Annual Subscription Cloud Based Anti-Plagiarism Software Service Customer Name: Geethanjali College of Engineering and Technology	997331	1.00 UNT	65,000.00	65,000.00	1,625.00 (2.5%)	1,625.00 (2.5%)	68,250.00
TOTAL (₹)					65,000.00	1,625.00	1,625.00	68,250.00

Bank Details:

Account Number : 31224292839
Bank Name : STATE BANK OF INDIA
IFSC : SBIN0011666
Branch Name : RAMAKRISHNAPURAM, Hyderabad

Taxable Amount ₹ 65,000.00

Total Tax ₹ 3,250.00

Total amount (in words) Sixty Eight Thousand Two Hundred Fifty Rupees Only

Total Amount ₹ 68,250.00

Notes:

As per Notification: "Goods and Service Tax concession certificate in terms of Notification No. 45/2017-Central Tax (Rate) Dated: 14th Nov 2017 & 9/2018-Central Tax (Rate) Dated: 25th Jan 2018/ Notification No. 47/2017-Integrated Tax (Rate) Dated: 14th Nov 2017 Issued by the Ministry of Finance Department of Revenue of Government of India." The above exempted tax notification has been mentioned in the PO copy by Geethanjali College of Engineering and Technology. We have charged the exempted GST rate @5% on the Invoice value instead of Normal rate @18% as applicable. In future if any tax liability or a Notice raised by the Concerned GST Departments, the same GST liability will have to be borne by the Geethanjali College of Engineering and Technology Only. We (Pinnacle Nanotech India Pvt Ltd) are not the responsible for any future Tax Liability for this particular transaction.

Pinnacle Nanotech India Pvt Ltd



Authorised Signatory

Terms & Conditions:

1. We declare that this invoice shows the actual price of the goods described and that all particulars are true and correct.
2. Subject to Hyderabad Jurisdiction.
3. Interest will be Charged @18% if not paid with in due date
4. TDS Not Applicable NOTIFICATION NO. 21/2012 S.O. 1323(E), DATED 13-6-2012

PAGE - 1

PRINCIPAL
Geethanjali College of Engg. and Tech.
Cheeryal (V), Keesara (M), Medchal Dist.(T.S.)-501 301..

TAX INVOICE

ORIGINAL FOR RECIPIENT



From

Pinnacle Nanotech India Pvt Ltd
11-8-237/4/204, C S Nilayam, Kranthi Nagar Colony,
Sarooranagar,, Hyderabad, Telangana 500035

GSTIN 36AAF4375H1Z7

PAN AAF4375H

Invoice No. : INV/TS/21110
Invoice Date : 23/12/2021
Reference No : GCET/CSE/PO/21-22, Dt:
16/11/2021
Place of supply : 36-Telangana
Due Date : 27/12/2021

Billing Address

Teja Educational Society
Geethanjali College of Engineering and Technology, Cheeryal
Village, Keesara Mandal, Hyderabad, Telangana 501301,
Telangana

Shipping Address

Teja Educational Society
Geethanjali College of Engineering and Technology, Cheeryal
Village, Keesara Mandal, Hyderabad, Telangana 501301,
Telangana

#	Description	HSN / SAC	Qty	Rate / Unit	Taxable Value	CGST	SGST / UTGST	Total Amount
1	DrillBit Extreme Anti Plagiarism software - 500 Document Submissions one user account 12 months Annual Subscription Cloud Based Anti-Plagiarism Software Service	997331	1.00 UNT	65,000.00	65,000.00	1,625.00 (2.5%)	1,625.00 (2.5%)	68,250.00
TOTAL (₹)					65,000.00	1,625.00	1,625.00	68,250.00

Bank Details:

Account Number : 1443280000000819

IFSC : KVBL0001443

Bank Name : Karur Vysya Bank

Branch Name : ABIDS, Hyderabad

Taxable Amount ₹ 65,000.00

Total Tax ₹ 3,250.00

Total amount (in words) Sixty Eight Thousand Two Hundred Fifty Rupees Only

Total Amount ₹ 68,250.00

Notes:

As per Notification: "Goods and Service Tax concession certificate in terms of Notification No. 45/2017-Central Tax (Rate) Dated: 14th Nov 2017 & 9/2018-Central Tax (Rate) Dated 25th Jan 2018/ Notification No. 47/2017- Integrated Tax (Rate) Dated 14th Nov 2017 issued by the Ministry of Finance Department of Revenue of Government of India." The above-exempted tax notification has been mentioned in the PO copy by Teja Educational Society (Geethanjali College of Engineering and Technology). We have charged the exempted GST rate @5% on the Invoice value instead of the Normal rate @18% as applicable. In future, if any tax liability or a Notice is raised by the Concerned GST Department, the same GST liability will have to be borne by the Teja Educational Society (Geethanjali College of Engineering and Technology) Only. We "Pinnacle Nanotech India Pvt Ltd" are not responsible for any future Tax Liability for this particular transaction.

Pinnacle Nanotech India Pvt Ltd



Authorised Signatory

Terms & Conditions:

1. We declare that this invoice shows the actual price of the goods described and that all particulars are true and correct.
2. Subject to Hyderabad Jurisdiction.
3. Interest will be Charged @18% if not paid with in due date
4. TDS Not Applicable NOTIFICATION NO. 21/2012 S.O 1323(E), DATED 13-6-2012

PRINCIPAL
Geethanjali College of Engg. and Tech.
Cheeryal (V), Keesara (M), Medchal Dist.(T.S.)-501 301.

PAGE - 1

TEJA EDUCATIONAL SOCIETY(GCET)

Sub-Ledger Pinnacle Nanotech India Pvt.Ltd 01-04-2018 To 31-03-2019

Date	Voucher	Cheq. No	Name	Debit	Credit	Balance	Narration
Pinnacle Nanotech India Pvt.Ltd							
			Opening Balance	53,000.00		53000.00Dr	
08-01-2018	Jrn:386		Computer Peripherals & Maintenance		53,000.00		Towards Invoice No:INV/TS/18016
11-28-2018	Jrn:737		Software Equipment		76,700.00	76700.00Cr	Towards Invoice No:HYD18013 (Anti Plagarisam Software)
12-24-2018	Pmt:3362	611683	CANARA BANK-(OD-A/c.No:55580-TEJA)	76,700.00			Towards Paid for Due Bill
02-02-2019	Pmt:3898	742808	CANARA BANK-(OD-A/c.No:55580-TEJA)	350,000.00		350000.00Dr	Towards Paid for PO due bill
03-31-2019	Jrn:1177		Computer Peripherals & Maintenance		350,000.00		Twds.MS Cloud software reneval vide bill no.TS/18060
Total (Rup)				479,700.00	479,700.00		

TEJA EDUCATIONAL SOCIETY(GCET)

Sub-Ledger Pinnacle Nanotech India Pvt.Ltd 01-04-2019 To 31-03-2020

Date	Voucher	Cheq. No	Account	Debit	Credit	Balance	Narration
Number	R.no	Amount					
Pinnacle Nanotech India Pvt.Ltd							
11-22-2019	Pmt:2736	308958	CANARA BANK-(OD-A/c.No:55580-TEJA)	65,100.00		65100.00Dr	Towards paid for PO Advance
01-09-2020	Jrn:854		Software Equipment		65,100.00		Towards Invoice No:Inv/TS/19036
02-24-2020	Pmt:3940	620920	CANARA BANK-(OD-A/c.No:55580-TEJA)	341,040.00		341040.00Dr	Towards Paid for PO Advance
Total (Rup)				406,140.00	65,100.00		

TEJA EDUCATIONAL SOCIETY(GCET)

Sub-Ledger Pinnacle Nanotech India Pvt.Ltd 01-04-2020 To 31-03-2021

Date	Voucher	Cheq. No	Account	Debit	Credit	Balance	Narration
Pinnacle Nanotech India Pvt.Ltd							
			Opening Balance	341,040.00		341040.00Dr	
04-02-2020	Jrn:27		Internet & Website Charges		341,040.00		Towards Invoice No:INV/TS/20001
11-23-2020	Jrn:626		Computer Peripherals & Maintenance		101,700.00	101700.00Cr	TOWards Invoice No:HYD 20006 (Pur.of Xp- Pen Stars)
11-24-2020	Pmt:1435	271909	CANARA BANK-(OD-A/c.No:55580-TEJA)	101,700.00			Towards Paid for Due Bill
12-05-2020	Pmt:1555	643258	SBI Bank -a/c(PGCET-62079625817)	68,250.00		68250.00Dr	Towards Paid for PO Advanve
02-09-2021	Jrn:996		Software Equipment		68,250.00		Towards Invoice No:INV/TS/20041 (Pur.of Anti Plagarism Software)
02-19-2021	Pmt:2264	585005	Canara Bank C/A.no(GCET-21980)	372,750.00		372750.00Dr	Towards paid for PO Advance
03-29-2021	Jrn:1313		Software Equipment		372,750.00		Towards Invoice No:INV/TS/20053
Total (Rup)				883,740.00	883,740.00		

PRINCIPAL
 Geethanjali College of Engg. and Tech.
 Cheeryal (V), Keesara (M), Medchal Dist.(T.S.)-501 301



To
The Principal,
Geethanjali College of Engineering and Technology
Hyderabad.

Date: 06-03-2020

Sub: Research project "Eco-friendly Blackboard Eraser System" – regarding.

Respected Sir,

The manual method of erasing the blackboard with a duster is time consuming and a tedious process. It breaks concentration of both lecturers and listeners. Chalk dust produced while erasing the blackboard causes serious health problems to both students and teachers.

To overcome these problems, I discussed about a research project "Eco-friendly Blackboard Eraser System" as one of the alternatives with B.Tech (ECE) IV student Mr. M. Eswar Hemant (Roll No. 16R11A0427 in Section A). It will reduce the time consumed to erase the blackboard and also the human effort. I hereby propose that under my guidance and supervision, the student Mr. M. Eswar Hemant will design the above project and implement it with sponsorship from our institution in a classroom environment. The amount needed is estimated to be Rs.30,000/- (Rupees Thirty Thousand only) for the sliding equipment, electrical components, fabrication of gears/racks, electronic components and wooden box preparation. This is for your kind perusal and approval.

Thanking you,

Yours Sincerely,

O.V.P.R. Siva Kumar,
Professor of ECE

*Forwarded to
The Principal
for consideration
06/03/2020*

*Approved -
Siva*

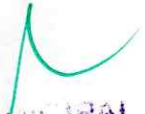
PRINCIPAL
Geethanjali College of Engg. Tech.
Cheeryal (V), Keerasa (M), R.R. Dist. (A.P.) - 501 301

"Eco-friendly Blackboard Eraser System" - an innovative project implemented by Mr. M. Eswar Hemanth (Roll No. 16R11A0427), a student of IV B.Tech (ECE) executed under the guidance of Prof.O.V.P.R. Siva Kumar in the classroom of Department of ECE and funded by GCET management

Blackboard is essential for every educational institution. The manual method of erasing the blackboard with a duster is time consuming and a tedious process. It breaks concentration of both lecturers and listeners. Chalk dust produced while erasing the blackboard causes serious health problems to both students and teachers. To overcome these problems, Remote Controlled Eco-friendly Blackboard Cleaner is one of the alternatives. It will reduce the time consumed to erase the blackboard and also the human effort.

Remote controlled eco-friendly blackboard cleaner is a machine which cleans a whiteboard or a blackboard automatically with press of a button of a remote device. This machine uses RF and a DC motor to move the duster in horizontal (X-axis) direction to cover the whole whiteboard area and DC Fans are used to suck the chalk dust particles produced. As an additional feature, the GSM module sends an SMS as a reminder to the faculty about the upcoming scheduled class.

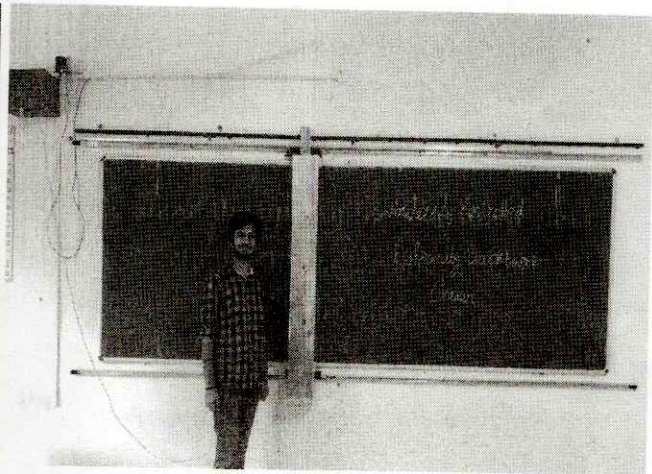
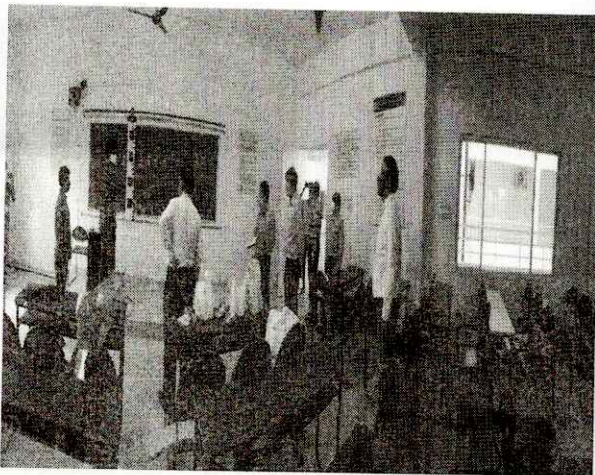

The project was designed and implemented by Mr. M. Eswar Hemanth of ECE IV year (Section E, Roll No. 16R11A0427) under the guidance of Prof.O.V.P.R. Siva Kumar. He conceived this project in the interest of faculty's health and it took a great effort to scale up a small prototype into a real time project for a class room. Many factors were considered while implementing it and he faced several hurdles during the course of the project execution. However, he never gave up and at last successfully completed this project with the support of college management and faculty from department of ECE and department of Mechanical Engineering. Even in the pandemic situation of Covid-19, he worked very hard for the smooth implementation of the project in Geethanjali College of Engineering and Technology. A demo of this project was given

on Aug 26, 2020 to our Chairman, Principal, Dean, SE&CE, HoD-ECE and senior professors of Dept. of ECE. All of them appreciated the project and encouraged the student for the effort.

Patent application with title "**Eco-friendly Blackboard Eraser System**" was published on 26/02/2021 with the Official Gazette of the Indian Patent Office with reference No. 202141007015. Mr. Majeti Eswar Hemant is the applicant and inventor, and Mr. Ogirala Venkata Pandu Ranga Sivakumar is the Co-applicant and Co-inventor.

Prof.O.V.P.R. Siva Kumar

Department of ECE, GCET

PRINCIPAL
Geethanjali College of Engg. Tech.
Chesyal (V), Kasara (M), R.R. Dist. (A.P.) - 501 301

To
The principal,
Geethanjali College of Engineering and Technology.

Subject - A request to fund our project-AUTOMATED TITRATOR

Respected Sir,

This is to inform you that we dealing with a project since several months and we have spent around **Rs.14,000/-** . To complete our model and make it patent ready we additionally require components which cost around **Rs. 18,860/-** which makes a grand total of **Rs.32,860/-**

We would be grateful if you could fund the whole project. We assure you that we will utilize the maximum time of this pandemic and make sure is patent ready within a month. Please do the needful and oblige.

The list of additional components required is mentioned below.

S.No	Component	Quantity	Price	Total
1.	Burette stand	2	900/-	1800/-
2.	Burette clamps	2	300/-	600/-
3.	Glass flask(250ml)	1	400/-	400/-
4.	Borosilicate glass burette (50ml)	1	1700/-	1700/-
5.	Matrix shield(4x3)	1	440/-	440/-
6.	Magnetic stirrer	1	8000/-	8000/-
7.	16x2 LCD	1	100/-	100/-
8.	I2C LCD module	1	150/-	300/-
9.	PCF8574T IO Expansion module	1	300/-	300/-
10.	Ac to Dc 5v step down transformer	3	450/-	1350/-
11.	Stepper motor with driver	2	260/-	520/-
12.	Fiber finishing including man work	-	3500/-	3500/-
	Funds further required			18860/-
	Funds already spent			14,000/-
	Funds Requested			32,860

Thanking you,
Yours sincerely,

M.SUNNY RAJ - 19R11A05N4 (CSE) *[Signature]*
7/9/20 [9705258299]

G.ABHINAV-19R11A04M0 (ECE)
[Signature] 7/9/20 (6309461812)

Project Mentor

[Signature]
(P. Navesh Kumar) 7/9/2020.

Incubation center shall monitor the project.

- I/c Incubation center

Dr. Puppala *[Signature]*

[Signature]
Ac
Adv-forg chr
M

Submitted to Secretary for
approval.

[Signature] 08/09/20

[Signature]
Secretary

PRINCIPAL
Geethanjali College of Engg. and Tech.
Cheerayal (V), Keesara (M), Medchal Dist.(T.S.)-501 301.

Form to request reimbursement for the project sanctioned in Incubation CenterDate: 06/07/2021

Project Title: Automated Titrator

Name of the Mentor: P.Naresh Kumar, Assistant Professor. Dept of ECE.

S.No	Name of the team member	Dept	Roll No.	Phone	Email ID
1	M.SUNNY RAJ	CSE	19R11A05N 4	970525829 9	mysonsunnyraj@gmail.com
2.	G.ABHINAV	ECE	19R1A04M0	630944181 2	abhinavgorthy@gmail.com

Project sanction letter Reference date: 7th Sep 2020

The following parts/items were purchased for the project Automated titrator.

S.No	Name of the part	Bought from the company	Price
1.	Magnetic stirrer 1 liters-Remi	Scientific World	7729/-
2.	Retort Stand (9x6) Ord	Scientific World	1003/-
3.	Burette-50ml BOROSILICATE	Scientific World	306/-
4.	CONICAL FLASK-250ml	Scientific World	141/-
5.	Fisher clamps (2)	Scientific World	212/-
6.	Burette 50ml-N-Borosil	Scientific World	967/-
7.	Gears Assorted.	Modern Electronics	295/-
8.	L clamp	Modern Electronics	201/-
9.	5v/12v/1amp adapter	Modern Electronics	425/-
10.	Lcd 12c display	Modern Electronics	236/-
11.	A4988 module	Modern Electronics	177/-
12.	Nema 17 Motor	Modern Electronics	838/-
13.	Jumper wires (M-M) (M-F)(F-F)	Modern Electronics	283/-
14.	Keypad 4*3	Modern Electronics	295/-
15.	I/O expansion pcf8574	Modern Electronics	354/-
16.	T86600 module	Modern Electronics	826/-
17.	24v/5amp power supply	Modern Electronics	649/-
18.	Nema 23/30kg	Modern Electronics	3000/-
19.	Nuts & bolts	HIC Fasteners	85/-
20.	2mm Key	HIC Fasteners	15/-
21.	Black box (30)	Maker Global	5605/-
22.	Pcb along With design	Pcb board - Modern ,Soldering - Koti Shop vendor	380/-
23.	Mechanical model Building along with nylon finish	Hardware Workshop- Ranigunj	2100/-

TOTAL - 26022/-

PRINCIPAL
Geethanjali College of Engg. and Tech.
Cheerayal (V), Keerasa (M), Medchal Dist.(T.S.)-501501

Prior to this, we have submitted a document on 7th September 2020, where we have mentioned the amount we spent i.e. 13,750/- and a rough estimate of Rs.18,860/- to finish the whole project which indeed makes a grand total of 32,860/-

Whilst pursuing our project, there were few changes and we needed to add some extra components as well.

- Firstly, the **TB6600** color sensor gives accurate reading when the surrounding is dark. For this we 3D printed a black box of dimensions 14cm x14cm x11cm and kept it hollow so that burette can kept inside it.
- Secondly, the stepper motor which we mentioned is small so we needed to replace it with a bigger one (**NEMA- 23/30kg**)
- Finally, we had to include a power supply to Motor as well as the color sensor.

Considering these, the budget exceeded by Rs.7162/- . The cost of each is mentioned below

S.No	Product	Estimated cost	Actual cost
1.	Black box	0/-	5605/-
2.	Stepper Motor(Nema-23)	540/-	3000/-
3.	Magnetic stirrer	8000/-	7729/-
4.	Burettes (Borosilicate)	1700/-	1273/-
5.	Burette Stand	1800/-	1003/-
6.	Fischer Clamps	600/-	212/-
7.	Conical flask	400/-	141/-
8.	TB6600 Module	0/-	826/-
9.	Mechanical work	3500/-	2000/-
10.	Power supply	1350/-	649/-

Here, there is a difference between the actual amount and estimated amount. We have included additional components and eliminated a few. The actual prices of some products is quite less than expected.

PRINCIPAL
Geethanjali College of Engg. and Tech.
Cheerayal (M), Keesara (M), Taddei District, West Godavari Dist.

We request you to kindly reimburse the same from the project poster describing the complete project and a report of the same. Soft and hard copies of the invoices are being submitted along with this request note.

Thanking You

S.No	Team Member 1	Team Member 2
Name	M.SUNNY RAJ <i>30/6/21</i>	G. ABHINAV <i>30/6/21</i>
Phone	9705258299	6309441812
Email ID	mysonsunnyraj@gmail.com	abhinavgorthy@gmail.com
Department	CSE	ECE
Designation	2 nd year student	2 nd year student
Roll Number / Faculty ID	19R11A05N4	19R11A04M0
Year of study if Applicable	2019-2023	2019-2023

Faculty mentor should check the boxes applicable		Name	P NARESH KUMAR
Received the following		Email ID	naresh.ece@gcet.admin
Kit and/or software code	S/W Code	Department	ECE
Chart/Poster	-	Phone	9866373432
Soft Copy (only) of Report	-	Mentor's Comments for the next step	Major part of the exp Project Completed 90%. Testing Part need to be done.
Soft copies of the certificates of any competitions participated, won prizes	Merit/award certificate: -	Signature	<i>[Signature]</i> 30/06/2021
Relevant forms for filing IP	-		

Advance Amount - 13750/-
 Total Expenditure - 39772/-
 Sanctioned Amount - 32860/-
 In charge of the Incubation Center:

Additional expenditure: 7162/-
 Additional amount was due to trail and error of some components and unexpected increase in price.

Comments	The team shall submit another copy of this form after project completion. It is understood that major portion of the work is completed and mentor is monitoring the progress.
Date & Signature	<i>[Signature]</i> Dr. Anil Kumar Puppala 30 th Jun 2021

PRINCIPAL
 Geethanjali College of Engg and Tech.
 Cheeryal (V), Keesara (M), Medchal Dist.(R.S.)-501 301.

We request you to kindly reimburse the same from the project sanctioned. We shall submit the kit, a poster describing the complete project and a report of the same. Soft and hard copies of the invoices are being submitted along with this request note.

Thanking You

S.No	Team Member 1	Team Member 2
Name	M.SUNNY RAJ <i>30/6/21</i>	G. ABHINAV <i>30/6/21</i>
Phone	9705258299	6309441812
Email ID	mysonsunnyraj@gmail.com	abhinavgorthy@gmail.com
Department	CSE	ECE
Designation	2 nd year student	2 nd year student
Roll Number / Faculty ID	19R11A05N4	19R11A04M0
Year of study if Applicable	2019-2023	2019-2023

Faculty mentor should check the boxes applicable		Name	P NARESH KUMAR
Received the following		Email ID	naresh.ece@gcet.edu.in
Kit and/or software code	S/W Code	Department	ECE
Chart/Poster	-	Phone	9866373432
Soft Copy (only) of Report	-	Mentor's Comments for the next step	Major part of the exp project completed 90%. Testing part need to be done.
Soft copies of the certificates of any competitions participated, won prizes	Merit/award certificate:		
Relevant forms for filing IP		Signature	<i>P. N. Kumar</i> 30/06/2021

In charge of the Incubation Center:

Comments	The team shall submit another copy of this form after project completion. It is understood that major portion of the work is completed and mentor is monitoring the progress.
Date & Signature	<i>[Signature]</i> Dr. Anil Kumar Puppala th 30 Jun 2021

Geethanjali
Cheerla (V), Keesara (M), Medchal Dist. (A.S.) 501 501.

Date	Voucher	Cheq. No.	Account	Debit	Credit	Balance	Narration
Students Project Expenses							20-21
09-17-2020	Jrn:294		O.V.P.R.Siva Kumar	29,998.00		29998.00Dr	Towards paid for ECE (16-427) Project Implementation Misc Exp
09-21-2020	Pmt:766	983777	SBI Bank -a/c(PGCET-62079625817)	13,750.00		43748.00Dr	Towards Project Exp.paid to P.Naresh Kumar for Automated Titrator
12-05-2020	Pmt:1551	643260	SBI Bank -a/c(PGCET-62079625817)	1,000.00		44748.00Dr	Towards Paid to V.R.RAHUL (16-5E2) for Project Exp Prize Money
12-05-2020	Pmt:1552	643261	SBI Bank -a/c(PGCET-62079625817)	1,000.00		45748.00Dr	Towards Paid to P.VUTHAM (16-5C5) for Project Exp Prize Money
12-17-2020	Pmt:1710	643305	SBI Bank -a/c(PGCET-62079625817)	1,500.00		47248.00Dr	Towards Paid to S.SUHANT (16-5D7) for Project Exp Prize Money
01-02-2021	Pmt:1845	643324	SBI Bank -a/c(PGCET-62079625817)	1,500.00		48748.00Dr	Towards Paid to J.ASHISH REDDY (16-5A8) for Project Exp Prize M
01-13-2021	Pmt:2514	643284	SBI Bank -a/c(PGCET-62079625817)	1,500.00		50248.00Dr	Towards Paid to CH.Prathyusha (16-5A4) for Project Exp Prize Mon
01-29-2021	Pmt:2071		Main Cash Book	700.00		50948.00Dr	Towards Paid to S.Ramya18-488) for Project Components Exp
			Total (Rup)	50,948.00			

PRINCIPAL
Geethanjali College of Engg. and Tech.
Cheerla (V), Keesara (M), Medchal Dist.(T.S.)-501 301.

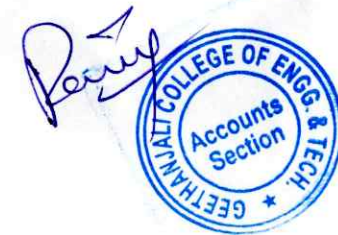

To
The Principal,
Geethanjali College of Engineering and Technology
Hyderabad.

Date: 20-10-2020

Sub: Research project "Water flow meter – Proof of Concept" – regarding.

Respected Sir,

As drinking water has to be treated as a scarce resource, the water leakage from the huge water pipelines running through several kilometers needs to be monitored periodically and corrective actions are to be taken up swiftly. To address these requirements and implement a smart engineering solution, a research project is envisaged, about which I discussed with our II B.Tech (ECE) students.

Srilekha Mopidevi -	18R11A0478
Ramya Samala	18R11A0488
Guddeti V Charan Kalyan	18R11A0466
Ruchishwa	18R11A0490

It's proposed that for developing proof of concept and subsequent knowledge transfer, we collaborate with SmartBridge Solutions Pvt. Ltd. The price quoted by Smartbridge for this purpose is Rs.30,000 (Rupees Thirty Thousand Only), which is attached for your kind perusal and approval.

Thanking you,

Yours Sincerely,



O.V.P.R. Siva Kumar,
Professor of ECE

*Forwarded
to the Principal
for kind consideration
20/10/2020.*

*Approved -
She*

[Signature]
PRINCIPAL
Geethanjali College of Engg. Techn.
Cheeryal (V), Keesara (M), R.R. Dist. (A.P.) - 501 301

Water Flow Meter –Model 1

The Water flow meter will continuously monitor the water flow and volume and store it in the Sd card.

Features:

- The system calculates the Flow Rate and Volume of water using flow sensors.
- It stores the entire information like flowrate and volume in the SD card for every time interval along with date and time.
- RTC module is used to get the date and time
- The device is integrated with the LCD display on which we can display the flow rate and volume.

Technical Architecture:

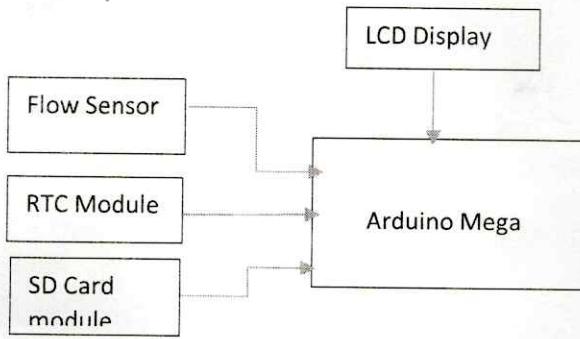

Bill of Materials:

Component
Arduino Mega 2560 REV3 with USB cable
Micro SD card module
DS3231 RTC Module
YF-S201 Water Flow Measurement Sensor with 1-30Liter/min Flow Rate
16x2 LCD Display
3D printed Enclosure
SanDisk Ultra 8 GB MicroSDHC Class 10
Miscellaneous items

The Total cost of Hardware and Development cost for the POC development of Model 1 is INR 30,000 + 18 % GST .

Project time Duration is 1 month.

PRINCIPAL
 Geethanjali College of Engg. Tech.
 Cheeryal (V), Keosara (M), R.R. Dist. (A.P.) - 501 301



Water Flow Meter –Model 1

The Water flow meter will continuously monitor the water flow and volume and stor card.

Features:

- The system calculates the Flow Rate and Volume of water using flow sensors.
- It stores the entire information like flowrate and volume in the SD card for eve interval along with date and time.
- RTC module is used to get the date and time
- The device is integrated with the LCD display on which we can display the flow volume.

Technical Architecture:

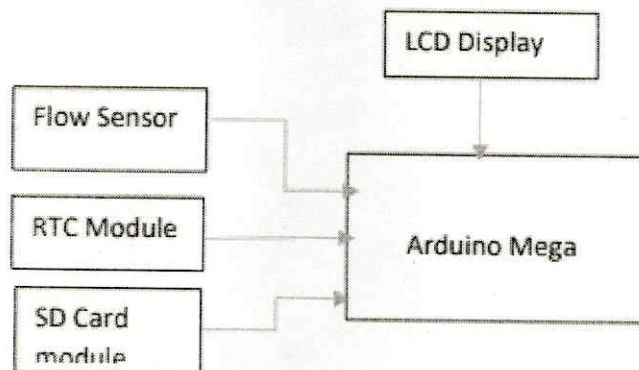

Bill of Materials:

Component
Arduino Mega 2560 REV3 with USB cable
Micro SD card module
DS3231 RTC Module
YF-S201 Water Flow Measurement Sensor with 1-30Liter/min Flow Rate
16x2 LCD Display
3D printed Enclosure
SanDisk Ultra 8 GB MicroSDHC Class 10
Miscellaneous items



Handwritten signature
PRINCIPAL
 Geethanjali College of Engg. Tech.
 (Bapatla), Keosara (M), R.R. Dist. (A.P.) - 501 301

2020-21

JUN
1456

31/10/2022

TAX INVOICE

Bill to	Place of Supply			Invoice No.	Dated
Geethanjali College of Engineering & Technology	Cheeryala (V) Keesara (M), Rangareddy Dist. Telangana, Hyderabad-501301.			GST/2020-21/15	31/10/2020
				Buyer's PO No.	Dated
GSTN :				GCET/PO/R&D/06/20-21	28/10/2020
DESCRIPTION OF GOODS / SERVICE	HSN CODE	QTY.	UNITS	RATE, Rs.	AMOUNT, Rs.
Development of Water flow meter containing hardware and Software to monitor the flow and total water consumed.	440414	1	No	30000	30000
				Add GST 5%	1500
				Amount Received	31500
Amount Chargeable (in words) Thirty one thousand Five hundred Rupees only	Notes: Development support of Water flow meter and POC Development..			For SmartBridge Educational Services Pvt. Ltd	
Company's Details: PAN No.: AAWC3611C GSTIN : 36AAWCS3611C1ZC BANK: ICICI BANK LIMITED A/C.No.: 007605500462 IFSC CODE: ICIC0000076				  Authorized Signatory	

PRINCIPAL
Geethanjali College of Eng. Tech.
(V), Keesara (M), R.R. Dist. (M.P.) - 501 301

ALL
Adw NEFT Paid
SBS - (183648)
Cheque
on 03/11/2020
Permy



Geethanjali

Phone : 9182058186
 Website: www.geethanjaliinstitutions.com
 info@gcet.edu.in

Geethanjali College of Engineering and Technology

AUTONOMOUS

(Accredited by NBA, Approved by AICTE, New Delhi)

Sy.No. 33 & 34, Cheeryal (V), Keesara (M), Medchal District. - 501 301.

PURCHASE ORDER

Our Ref. : GCET/PO/R&D/06/20-21

Date: 28-10-2020

Your Ref. : Your quotation No. Dt. 22-10-2020

To

M/s SmartBridge Educational Services Pvt. Ltd.,
 Plot No 132, Bapuji Nagar, Habsiguda, Above DCB bank, 2nd floor, Nacharam Main Road,
 Hyderabad – 500 076, Ph: 9849334539

Sub: Supply of Water flow meter for Proof of Concept (PoC) – Reg.

With reference to your quotation cited above and personal negotiations we had with you, we are pleased to place the purchase order on your firm for the following items, as per the specifications, terms & conditions indicated.

S.No.	Name of the item	Qty	Unit cost (Rs)	Total Cost (Rs)
01	Water flow meter containing hardware and software to monitor the flow and total water consumed. Detailed specifications are attached.	01 No.	30,000	30,000
			Total	30,000

(Rupees: Thirty Thousand Only)

Terms & Conditions:

Payment : 100% in advance
 Delivery : within one month from the date of purchase order
 Taxes : 5%

Please acknowledge the receipt of the P.O and arrange to supply as agreed upon.

For Geethanjali College of Engineering & Technology

D, ECE

 PRINCIPAL

 PRINCIPAL/SECRETARY

Geethanjali College of Engg. Tech.

Cheeryal (V), Keesara (M), R.R. Dist. (A.P.) - 501 301

Sponsored by TEJA EDUCATIONAL SOCIETY, HYDERABAD

Office : Sy. No. 33 & 34, Cheeryal (V), Keesara (M), Medchal Dist. - 501 301.

Phones : 9182058196, 9182058198

SmartBridge Educational Services Pvt. Ltd.
 Plot No 132, Bapuji Nagar, Above DCB Bank,
 2nd floor, Nacharam main Road, Habsiguda,
 Hyderabad, Telangana 500076
 IN
 9550678615
 PAN No. AAWCS3611C



Delivery Challan

BILL TO
 Geethanjali College of
 Engineering & Technology
 Cheeryala (V) Keesara (M),
 Rangareddy Dist.
 Telangana, Hyderabad-
 501301.
 State Code: 36

INVOICE NO. GST/2020-21/10-219
 DATE 17/07/2021

DATE	ACTIVITY	DESCRIPTION	QTY
06/02/2021	Services	Arduino Mega 2560	1
06/02/2021	Services	Water Flow Sensor - YF-S201	1
06/02/2021	Services	Micro SD Card Reader Module	1
06/02/2021	Services	LCD Display 16X2	1
06/02/2021	Services	DS1307 Real Time Clock	1

Geethanjali College of Engg. & Tech.
 INWARD
 Sl. No. 1872 Time 10:30 AM
 Date 09/08/2021
 Vehicle No. By hand
 Signature



PRINCIPAL

Geethanjali College of Engg. Tech.
 Cheeryala (V), Keesara (M), R.R. Dist. (A.P.) - 501307

SmartBridge Educational Services Pvt. Ltd.
 www.thesmartbridge.com | Email: amar@thesmartbridge.com

Date	Voucher	Cheq. No	Branch	Account	Debit	Credit	Balance	Narration
R & D Project Expenses(GCET)								
10-31-2020	Jrn:1456			Smartbridge Educational Services P	31,500.00		31500.00Dr	Towards Invoice No:GST/2020-21/15 ✓
				VT LTD				
				Total (Rup	31,500.00			



PRINCIPAL

Geethanjali College of Engg. Tech,
heeryal (V), Keesara (M), R.R. Dist. (A.P.) - 501 804



Date: 13/11/2019

To,

The Principal,

Geethanjali College of Engineering and Technology,

Cheeryal (V), Keesara (M).

Respected Sir,

Sub: Payment request for fabrication of Robot – Reg

I Y.V.N. Phani Kishore working as assistant professor in the department of CSE, would like to get to your notice that as part of robotics club of our college, we have been working on a robot (humanoid) which would be the anchor for the upcoming events in our college.

The software aspects of the robot are complete and would like to request you to permit us to go ahead in building the hardware required for the bot.

Approximate cost of procurement of the hardware and fabrication would be around 3,80,800/-

Attached is the expenditure incurred in fabricating the robot.

I request you to kindly approve the same.

Thanking You,

No check
SW
12/11/19

name
please correct

Yours Sincerely,

Y.V.N. Phani Kishore

Assistant Professor & Robotics club incharge

Department of CSE,

Geethanjali College of Engineering and Technology

Principle lets go ahead
Negotiate the rate

It appears that students are indeed passionate about working on this project. If completed and executed successfully would inspire several students to take up such projects. However the outcomes we may give a try

Submitted to Secretary for approval.

PRINCIPAL
Geethanjali College of Engg. and Tech.
Cheeryal (V), Keesara (M), Medchal Dist.(T.S.)-501 301.
13/11/19



Geethanjali

Phone . 9182058187
Website: www.geethanjaliinstitutions.com
info@gcet.edu.in

Geethanjali College of Engineering and Technology AUTONOMOUS

(Accredited by NAAC "A" Grade; ECE, CSE, EEE & ME, B.Tech Programs Accredited by NBA;
Approved by AICTE, New Delhi; Permanently Affiliated to JNTUH)
Sy. No. 33 & 34, Cheeryal (V), Keesara (M), Medchal District. - 501 301.

This is to whom to so ever it may concern

The college has agreed and sent a purchase order to M/S, build my project for construction and fabrication of humanoid robot.

this robot would be used for the purpose of educational awareness among the students of the college.

This robot will not be permitted to go out of the campus in any case and can solely be used for training and research activities in the campus only.

Regards,

Y.V.N. Phani Kishore

Incharge, Robotics Lab,

Geethanjali College of Engineering and Technology.

Ph: 9000208680

email: phanikishore.cse@gcet.edu.in

PRINCIPAL
Geethanjali College of Engg. and Tech.
Cheeryal (V), Keesara (M), Medchal Dist. (T.S.)-501 301.

Revised Quotation of Humanoid Robot messages

Tue, Sep 17, 2019 at 10:37 AM

Build my project <buildmyprojects@gmail.com>
To: Yvn Phanikishore <yvnphanikishore@gmail.com>

Hello sir,

As per our discussions i'm giving you costing of 4ft 6axis Humanoid Robot. We have designed 2 variants for you.

1) 4ft 6 axis : 2axis for neck, 2 axis for shoulders, 2 axis for elbow.
Cost: INR 2,30,000/- + 18% GST + Transportation

2) 4ft 6 axis : 2axis for neck, 2 axis for shoulders, 2 axis for gripping moment.
Cost: INR 2,50,000/- + 18% GST + Transportation

Let us ask this chap to come next week
Shr
9/17/19

Material used for making this robots is custom foam type material. Servicing of this Robot is very easy. You can easily replace any part in case of any damage. Servo motors are also custom made with 4th generation servos. All servo motors have metal gearing. The 2nd robot is enough cable to pick any ball, water glass or flower bouquet.

Bank Details Of Company:

Name: Build My Project
Account no: 60317074910
IFSC: MAHB0000635
Branch : tilak nagar, Dombivali

GST DETAILS:
BUILD MY PROJECT
27BAKPT9317C1ZF
PARSHIWADI, KOPARI COLONY, NEAR KAMINI APPT, THANE EAST - 400603

Thanks & Regards,
Pratik Tirodkar
CEO
Build My Project

Yvn Phanikishore <yvnphanikishore@gmail.com>
To: Anitha Goud <anithagouds@gmail.com>

Tue, Sep 17, 2019 at 10:55 AM

[Quoted text hidden]

PRINCIPAL
Geethanjali College of Engg. and Tech.
Cheeryal (V), Keesara (M), Medchal Dist.(T.S.)-501 301.



BUILD MY PROJECT
Way To Automation

PROFORMA INVOICE

BUILD MY PROJECT

COMPANY NAME: Build My Project
ADDRESS: 103, Nchate Niwas, Dr. R. P
Road, Domb East-
STATE CODE: 421201
GSTIN 27BAKPT9317C1ZF
BANKING DETAILS
Name: Build My Project
Branch: Tilak Nagar, Dombivli
A/C No.: 60317074910
IFSC Code: MAHB0000635

CUSTOMER NAME: Geethanjali
College of Engineering, Hyderabad
ADRESS: heeryal Village, Keesara
Mandal, Hyderabad, Telangana 501301
STATE CODE: 501301

PROJECT/SERVICE: 8 AXIS HUMANOID ROBOT

INVOICE NO: BMP041201

INVOICE DATE: 04-12-19

Sr. No.	Name of product & Description	Qty.	PRICE	AMOUNT INR
1.	High capacity Actuators for Neck, Shoulders, Thumb, Elbow(8	6,700	53,600
2.	Drivers, (L298N)	4	4,000/-	16,000/-
3.	3 D printed Parts	-	70,000	70,000/-
4.	Controller	1	4,500/-	4,500/-
5.	Lower body part with rover	1	70,000/-	70,000/-
6.	Software & designing	-	1,20,000	1,20,000/-
7.	Upper Body Part with Fabrication		70,000/-	70,000/-
8.	Electronic parts		52,924/-	52,924/-
TOTAL				4,57,024
DISCOUNTED AMOUNT				1,34,312
TOTAL PAYABLE AMOUNT				3,22,712
SGST			9%	29044.08
CGST			9%	29044.08
AMOUNT WITH GST				3,80,800.16/
TOTAL PAYABLE AMOUNT IN WORDS				THREE LAC EIGHTY THOUSAND EIGHT HUNDRED ONLY

TERMS: 100% PAYMENT BEFORE DISPATCHED

THANK YOU FOR YOUR BUSINESS!!

PRINCIPAL
Geethanjali College of Engg. and Tech.
Cheeryal (V), Keesara (M), Medchal Dist. (T.S.)-501 301.

www.bmpcourses.in

Mob: +91 8850809176/+91 7977543839

Email: buildmyprojects@gmail.com



BUILD MY PROJECT
Way To Automation

TAX INVOICE

BUILD MY PROJECT

COMPANY NAME: Build My Project
ADDRESS: 103, Nehate Niwas, Dr. R. P Road, Domb East-
STATE CODE: 421201
GSTIN: 27BAKPT9317C1ZF
BANKING DETAILS
Name: Build My Project
Branch: Tilak Nagar, Dombivli
A/C No.: 60317074910
IFSC Code: MAHB0000635

CUSTOMER NAME: Geethanjali
College of Engineering, Hyderabad
ADDRESS: heeryal Village, Keesara
Mandal, Hyderabad, Telangana 501301
STATE CODE: 501301

PROJECT/SERVICE: 5ft. 8AXIS HUMANOID ROBOT

INVOICE NO. BMP230601
INVOICE DATE: 23/06/2020

Sr. No.	Name of product & Description	Qty.	PRICE	AMOUNT INR
1.	5ft. 8 AXIS HUMANOID ROBOT	1	4,57,024/-	Rs.4,57024/-
TOTAL		-	4,57024/-	Rs.4,57024/-
DISCOUNTED AMOUNT		-	1,34,312/-	Rs.1,34,312/-
TOTAL PAYABLE AMOUNT		-	3,22,712/-	Rs.3,22,712/-
SGST		-	9%	Rs.29044.08/-
CGST		-	9%	Rs.29044.08/-
AMOUNT WITH GST		-	3,80,800.16/-	Rs.3,80,800.16/-
AMOUNT IN WORDS		-	-	THREE LAC EIGHTY THOUSAND EIGHT HUNDRED ONLY
TOTAL AMOUNT RECEIVED		-	1,90,000/-	Rs.1,90,000/-
REMAINING AMOUNT		-	1,90,800/-	Rs.1,90,800/-

Purchase & Stores
Goods Received
GR No. 061
Date 19.8.2020

THANK YOU FOR YOUR BUSINESS!!



Davies
SRUSHTI P.

Manager,
Build My Project.

Purchased by [Signature] Dept. of CSE
Inspected by K. K. [Signature]
Verified by [Signature]
15/08/2020

PRINCIPAL
Geethanjali College of Engg. and Tech.
Cheeryal (V), Keesara (M), Medchal Dist. (T.S.)-501 301.

w.bmpcourses.in Mob: +91 8850809176/+91 7977543839 Email: buildmyprojects@gmail.com



Geethanjali

Phone 040-32519687
Fax : +91-40-24220320
Website : www.geethanjalinstitutions.com

Geethanjali College of Engineering and Technology

(Accredited by NBA, Approved by AICTE, Now Delhi and Affiliated to JNTU, Hyderabad)
Sy.No. 33 & 34, Cheeryal (V); Keosara (M), Ranga Reddy District. - 501 301.

PURCHASE ORDER

GCET/ROBOTICS LAB/PO/2/19-20

Date: 5/12/2019

To,
M/s. Build My Project.
103, Nechate Niwas,
Dr. R.P. Road, Domb East,
Mumbai - 421201

Sub: Purchase of Humanoid Robot- Reg.

With reference to your quotation cited above and personal negotiations had with you, we are pleased to place the purchase order on your firm for the following items, as per specifications, terms & conditions indicated.

S.No	Name of the Product	Qty	Amount
1	High capacity Actuators for Neck, Shoulders, Thumb, Elbow with Motor Driver	1	1,50,000.00
2	Electro - Mechanical Parts	1	2,00,000.00
3	Fabrication of the Bot	1	2,05,000.00
4	Electrical Configuration	1	52,000.00
Total Amount			6,07,000.00
Discounted Amount			2,84,288.00
Total			3,22,712.00
GST			58,088.16
Total Amount with GST			3,80,800.16

PRINCIPAL
Geethanjali College of Engg. and Tech.
Cheeryal (V), Keosara (M), Medchal Dist.(T.S.)-501 301.

COMPANY NAME: Build My Project
ADDRESS: 103, Nehate Niwas, Dr. R. P Road, Domb East-
STATE CODE: 421201
GSTIN 27BAKPT9317C1ZF
BANKING DETAILS
Name: Build My Project
Branch: Tilak Nagar, Dombivli
A/C No.: 60317074910
IFSC Code: MAHB0000635

CUSTOMER NAME: Geethanjali College of Engineering, Hyderabad
ADDRESS: heeryal Village, Keesara Mandal, Hyderabad, Telangana 501301
STATE CODE: 501301

PROJECT/SERVICE: 5ft. 8AXIS HUMANOID ROBOT

INVOICE NO. BMP220901
INVOICE DATE: 22/09/2020

Sr. No.	Name of product & Description	Qty.	PRICE	AMOUNT INR
1.	5ft. 8 AXIS HUMANOID ROBOT	1	4,57,024/-	Rs.4,57024/-
TOTAL		-	4,57024/-	Rs.4,57024/-
DISCOUNTED AMOUNT		-	1,34,312/-	Rs.1,34,312/-
TOTAL PAYABLE AMOUNT		-	3,22,712/-	Rs.3,22,712/-
SGST		-	9%	Rs.29044.08/-
CGST		-	9%	Rs.29044.08/-
AMOUNT WITH GST		-	3,80,800.16/-	Rs.3,80,800.16/-
TOTAL AMOUNT IN WORDS		-	-	THREE LAC EIGHTY THOUSAND EIGHT HUNDRED ONLY

THANK YOU FOR YOUR BUSINESS!!



Praveen
SRUSHTI P.
 Manager,
 Build My Project.

PRINCIPAL
 Geethanjali College of Engg. and Tech.
 Cheeryal (V), Keesara (M), Medchal Dist.(T.S.)-501 301.

IFSC Code: MAHB0000000

केनरा बैंक



Canara Bank

HYDERABAD ABID ROAD SPLSD MID CORP BRANC Branch
HYDERABAD TELANGANA 500004
IFSC : CNRB0004926

Valid for three months only from the date of instrument

MULTI-CITY OD

13/12/2019
D D M Y Y Y Y

या धारक को Or Bearer

Pay Build My Project

Rupees रुपये One Lakh Ninety Thousand only

अदा करें

₹ 1,90,000/-

A/c. No. 060625655580

309011

For TEJA EDUCATIONAL SOCIETY

Authorised signatory

Please sign above

Payable at par at all our branches in India

⑈309011⑈ 500015070⑈ 000025⑈ 30

PRINCIPAL
College of Engg. and Tech.
Cheerla, Nalgonda (N), Medchal Dist. (T.S.)-501 301.

TEJA EDUCATIONAL SOCIETY(GCET)

Ledger

01-04-2020 To 31-03-2021

Page 1

Date	Voucher	Account	Debit	Credit	Balance	Narration
Software Equipment						
		Opening Balance	31,91,123.00		31,91,123.00Dr	
01-04-2020	Jrn:729	Bees Software Solutions Pvt.Ltd	2,85,000.00		34,76,123.00Dr	Towards Inv No:38 (Exam Branch Purpose Bees Software Purchased)
09-02-2021	Jrn:996	Pinnacle Nanotech India Pvt.Ltd	68,250.00		35,44,373.00Dr	Towards Invoice No:INV/TS/20041 (Pur.of Anti Plagarism Software) ✓
29-03-2021	Jrn:1313	Pinnacle Nanotech India Pvt.Ltd	3,72,750.00		39,17,123.00Dr	Towards Invoice No:INV/TS/20053 ?
		Total (Rupees)	39,17,123.00			2.26.
Robotics Laboratory Equipment (CSE)						
16-09-2020	Jrn:290	Build My Project	3,80,800.00		3,80,800.00Dr	Twds.Robot spares-CSE-Robotics Lab-Bill No.BMP230601/23.6.20 ✓
19-12-2020	Jrn:802	Kiran Embedded	9,950.00		3,90,750.00Dr	Towards Paid for Pur.of CSE Dept Robotics Lab Equipmnts ✓
		Total (Rupees)	3,90,750.00			
Computers Equipments						
		Opening Balance	7,00,83,042.00		7,00,83,042.00Dr	
01-09-2020	Jrn:574	S.V.Electronics Ltd	25,000.00		7,01,08,042.00Dr	Twds.cost of 2 No's Brother printers- B.No.2828
21-09-2020	Jrn:581	S.V.Electronics Ltd	12,500.00		7,01,20,542.00Dr	Twds.cost one brother printer & Toner B:3336/21.9.20
04-11-2020	Jrn:576	S.V.Electronics Ltd	16,400.00		7,01,36,942.00Dr	Twds.cost of 2 No's Brother printers- B.No.4492
26-11-2020	Jrn:773	S.V.Electronics Ltd	12,500.00		7,01,49,442.00Dr	Twds. cost Brother Printer-L-2520D model B.No.5008
22-02-2021	Jrn:1105	S.V.Electronics Ltd	58,500.00		7,02,07,942.00Dr	Towards Invoice No:C15-7157
31-03-2021	Jrn:1297	S.V.Electronics Ltd	75,41,311.00		7,77,49,253.00Dr	Towards Invoice No:C15-8144
		Total (Rupees)	7,77,49,253.00			76-66211
		Total (Rupees)	8,20,57,126.00			



31

PRINCIPAL
Geethanjali College of Engg. Techn.
Cheerpal (V), Keesara (M), R.R. Dist. (A.P) - 501 301

Geethanjali College of Engineering and Technology

An Autonomous Institution

Approved by AICTE and permanently affiliated to JNTUH, ISO 9000:2008 Certified

CENTRAL LIBRARY

Library Budget Approvals and Utilization(2016-17 to 2021-22)

(In Lakhs)

Year	Propasal Budget	Approval	Books	Journals	e-Resources	Total	Utilization %
	(Rs.)	(Rs.)	(Rs.)	(Rs.)	(Rs.)	(Rs.)	%
2016-17	21.30	17.50	6.57	5.06	5.54	17.17	98%
2017-18	23.35	20.35	7.22	3.86	6.79	17.87	75%
2018-19	20.00	20.00	8.27	4.56	6.01	18.84	94%
2019-20	25.45	25.00	9.35	4.99	6.31	20.65	83%
2020-21	31.42	29.52	4.73	5.57	6.32	16.62	66%
2021-22	37.66	36.25	12.91	6.02	8.80	27.73	76.5%

Budget Proposed & Approved

■ Propasal Budget (Rs.) ■ Approval (Rs.)

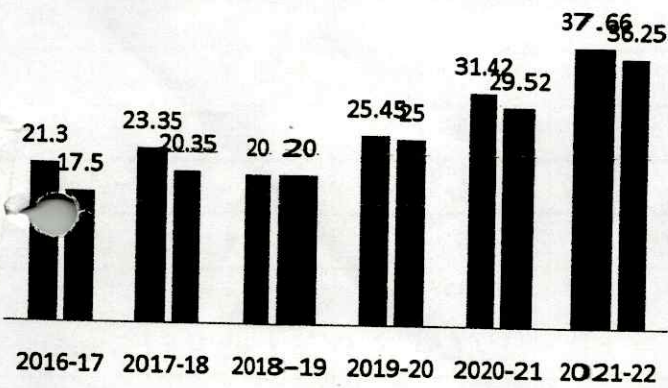

Approved & Utilization

■ Approval (Rs.Lakhs) ■ Utilization (Rs. Lakhs)

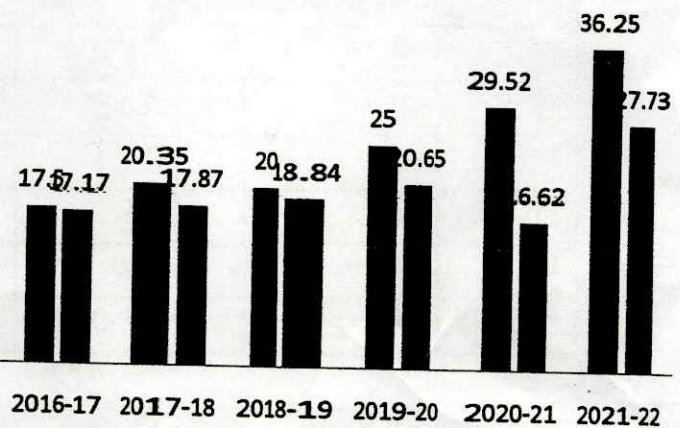

[Signature]
LIBRARIAN

LIBRARIAN

[Signature]
LAC Coordinator

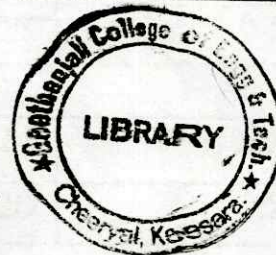

PRINCIPAL

Geethanjali College of Engg. & Tech.
Cheeryal (V), Keesara (M)
R.R. Dist. Pin-501 200

PRINCIPAL
Geethanjali College of Engg. and Tech.
Cheeryal (V), Keesara (M), Medchal Dist.(T.S.)-501 301.

NOTE

Date Number	Voucher	Account	Debit	Credit	Balance	Narration
Journals & Subscription						
		Opening Balance	8,607,863.00		8607863.00Dr	
01-30-2021	Jrn:1266	EBSCO Information Services India Pvt.Ltd	555,390.00		9163253.00Dr	Towards Invoice No:1/20-21/Jan-075
02-03-2021	Jrn:1207	SSR Subscription Agency	501,785.00		9665038.00Dr	Towards Invoice No:025
02-04-2021	Jrn:1144	Inventi Journals Pvt.Ltd	55,313.00		9720351.00Dr	Towards Invoice No:INV/2021/e/7283
02-15-2021	Jrn:1145	DELNET	13,570.00		9733921.00Dr	Towards Invoice No:DEL/202--21/2192
03-09-2021	Jrn:1412	Inflibnet-N List	5,900.00		9739821.00Dr	Towards Invoice No:NLIST/20-2/2722
03-10-2021	Jrn:1218	Infotrack Library Solutions	57,820.00		9797641.00Dr	Towards Invoice No:2509
		Total (Rupees)	9,797,641.00			
CACHE Books						
		Opening Balance	31,649.00		31649.00Dr	
		Total (Rupees)	31,649.00			
Text Books						
		Opening Balance	12,060,204.78		12060204.78Dr	
11-12-2020	Jrn:569	Bookionics	151,401.00		12211605.78Dr	Twds.purchase of books for library vide B.No.2135 9/4.11.20
11-28-2020	Pmt:1486	Main Cash Book	475.00		12212080.78Dr	Towards paid for Pur.of Text Books
12-07-2020	Jrn:766	Bookionics	29,655.00		12241735.78Dr	Twds.purchase of books for library vide B.No.21406
12-21-2020	Jrn:985	Bookionics	46,740.00		12288475.78Dr	Towards Invoice No:BI/21413
12-23-2020	Jrn:847	Bookionics	78,795.00		12367270.78Dr	Twds.purchase of Books for library - vide bill no.21414
01-19-2021	Jrn:986	Bookionics	22,558.00		12389828.78Dr	Towards Invoice No:BI/21484
02-04-2021	Jrn:1208	Bookionics	46,155.00		12435983.78Dr	Towards Invoice No:BI/21523
02-18-2021	Jrn:1413	Shah Book House Pvt.Ltd	39,139.00		12475122.78Dr	Towards Invoice No:SBH/12816 & SBH/12817
02-18-2021	Jrn:1413	Shah Book House Pvt.Ltd	25,059.00		12500181.78Dr	Towards Invoice No:SBH/12816 & SBH/12817
02-19-2021	Pmt:2281	Main Cash Book	3,903.00		12504084.78Dr	Towards Paid for Pur.of Text Books
03-25-2021	Jrn:1417	Bookionics	26,303.00		12530387.78Dr	Towards Invoice No:BI/21597
		Total (Rupees)	12,530,387.78			
		Total (Rupees)	22,359,677.78			

- 1189778/

Date	Voucher	Cheq. No	Branch	Account	Debit	Narration
19-06-20	Pmt:325		CIVIL	Main Cash Book	2,000.00	Towards paid to D.Varun Kumar (Civil) for Paper Publication Ince
19-06-20	Pmt:326		CIVIL	Main Cash Book	2,000.00	Towards paid to D.Rama Chande (Civil) for Paper Publication Ince
05-11-20	Pmt:1225		S&H	Main Cash Book	4,000.00	Towards paid to Dr.R.Sanjeev (S&H) for Paper Publication Incenti
30-12-20	Pmt:1816	643319	CSE	SBI Bank -a/c(PGCET-62079625817)	2,000.00	Towards Paid to J.Uma Mahesh (CSE) for NET Qualified Incentive
01-01-21	Pmt:1848		MECH	Main Cash Book	1,500.00	Towards Paid to J.Nithin Kumar (MECH) for Paper Publication Ince
11-01-21	Pmt:1934	643144	EEE	SBI Bank -a/c(PGCET-62079625817)	2,000.00	Towards paid to E.Hima Bindhu (EEE) for IEEE Conference Inective
30-01-21	Pmt:2073	643183	CSE	SBI Bank -a/c(PGCET-62079625817)	5,000.00	Towards paid to Dr.K.Kamakshaiah (CSE) for Book Publication Ince
30-01-21	Pmt:2074	643184	CSE	SBI Bank -a/c(PGCET-62079625817)	2,000.00	Towards paid to Dr.Rajesh Kumar Shrivastava (CSE) for Paper Publ
30-01-21	Pmt:2075	643185	MECH	SBI Bank -a/c(PGCET-62079625817)	2,000.00	Towards paid to R.Sudarshan (MECH) for Paper Publication Incenti
02-02-21	Pmt:2108	643193	CSE	SBI Bank -a/c(PGCET-62079625817)	2,000.00	Towards paid to K.Preethi (CSE) for Paper Publication Incentive
04-02-21	Pmt:2126	643199	CSE	SBI Bank -a/c(PGCET-62079625817)	2,000.00	Towards paid to G.Niveditha (CSE) for Paper Publication Incentiv
23-02-21	Pmt:2320	810139	ECE	SBI Bank -a/c(PGCET-62079625817)	10,000.00	Towards paid to Dr.R.Vijaya Durga (ECE) for Paper Publication Iv
02-03-21	Pmt:2406	810154	CIVIL	SBI Bank -a/c(PGCET-62079625817)	5,000.00	Towards paid to G.Sampath Kumar (Civil) for Papaer Publication I
04-03-21	Pmt:2433	810161	ECE	SBI Bank -a/c(PGCET-62079625817)	5,000.00	Towards paid to B.Ramu (ECE) for Papaer Publication I
10-03-21	Pmt:2510	810172	CSE	SBI Bank -a/c(PGCET-62079625817)	5,000.00	Towards paid to P.Preethi (CSE) for Paper Publication Incentive
10-03-21	Pmt:2511	810173	S&H	SBI Bank -a/c(PGCET-62079625817)	5,000.00	Towards paid to N.Nagireddy(S&H) for Paper Publication Incentive
10-03-21	Pmt:2512	810174	ECE	SBI Bank -a/c(PGCET-62079625817)	5,000.00	Towards paid to R.Odaiah (ECE) for Paper Publication Incentive
15-03-21	Pmt:2547	810181	ECE	SBI Bank -a/c(PGCET-62079625817)	5,000.00	Towards Paid to A.Shankar (ECE) for Paper Publication Incentive
15-03-21	Pmt:2548	810182	ECE	SBI Bank -a/c(PGCET-62079625817)	5,000.00	Towards Paid to CH.Sandeep (ECE) for Paper Publication Incentive
15-03-21	Pmt:2549	810183	CSE	SBI Bank -a/c(PGCET-62079625817)	5,000.00	Towards Paid to Dr.A.Hariprasad Reddy (CSE) for Paper Publicatio
17-03-21	Pmt:2598	810196	ECE	SBI Bank -a/c(PGCET-62079625817)	5,000.00	Towards Paid to P.Chandra Prakash Redd(ECE) for Paper Publicatio
17-03-21	Pmt:2599	810197	CSE	SBI Bank -a/c(PGCET-62079625817)	5,000.00	Towards Paid to K.Anusha (CSE) for Paper Publication Incentive
23-03-21	Pmt:2648	810205	ECE	SBI Bank -a/c(PGCET-62079625817)	5,000.00	Towards Paid to M.Laxmi (ECE) for Paper Publication Incentive
23-03-21	Pmt:2649	810206	S&H	SBI Bank -a/c(PGCET-62079625817)	5,000.00	Towards Paid to Dr.P.Raju (S&H) for Paper Publication Incentive
26-03-21	Pmt:2720	810216	CSE	SBI Bank -a/c(PGCET-62079625817)	5,000.00	Towards paid to Dr.Rajesh kumar Shrivastava (CSE) for paper Publ
				TOTAL	101,500.00	

PRINCIPAL
 Geethanjali College of Engg. and Tech.
 Cheeryal (V), Keesara (M), Medchal Dist.(T.S.)-501 301.



TEJA EDUCATIONAL SOCIETY (OCLT)
 Sub-Ledger Faculty Development Program Exp-A/c 01-04-2020 To 31-03-2021

Date	Voucher	Cheq. No	Branch	Account	Debit	Narration
18-05-20	Jrn:41		S&H	Dr.J.Shankar (S&H)	13,200.00	Towards FDP-(Physics-S&H)paid Honoratium&Zoom Video Inv-21125374
16-06-20	Pmt:261		ECE	Main Cash Book	300	TOWards paid to B.Sreelatha(ECE) for Android App DevelopmReg Fee
05-03-21	Pmt:2450		CSE	Main Cash Book	800	Towards paid to lochan Rampal For FDP On Cyber Security
05-03-21	Pmt:2451		IT	Main Cash Book	800	Towards paid to Radhika Amareshawari For FDP On Cyber Security
06-03-21	Pmt:2456		CSE	Main Cash Book	2,300.00	Towards paid to M.Ajay kumar & E.Mahendar (CSE) for FDP Reg Fee
06-03-21	Pmt:2456		CSE	Main Cash Book	2,300.00	Towards paid to M.Ajay kumar & E.Mahendar (CSE) for FDP Reg Fee
				TOTAL	19,700.00	



Geethanjali College of Engg. and Tech.
 Chennai 60, Hebbur (M), Madhurai Dist. (T.S.)-601 301.